

EMM

End of Line Monitoring Module

Summary

The iMAC EMM Module is an Intrinsically Safe Relay output module for the iMAC System. The iMAC EMM monitors the unique ‘Signal Line Healthy’ signal from the iMAC EOL (End of Line) Module to provide an alternative control relay (CR) output for the iMAC System. There are three EMM variants to suit 24 VDC, 110 VAC, or 240 VAC power supplies.

The EMM can be used with 2-wire and 3-wire iMAC fieldbus systems and requires EOL module data to operate.

Provides a fully independent verification of EOL module data and can be used to provide higher levels of safety.

The EMM monitors the iMAC fieldbus and energises its relay output whenever valid EOL data from the end of line module is detected. If invalid or no EOL data is detected, the relay output is de-energised.



Data Register(s)

1 (Output)

Features

- Intrinsically Safe IECEx [Ex ia] Group I Ma
- Provides an alternative to iMAC Controllers Control Relay
- iMAC Fieldbus electrically isolated
- Variety of power supply options
- Power healthy LED
- CR indication LED
- Multifunction diagnostic status LED
- Remotely controlled via the iMAC Controller
- Standard DIN rail or foot mounting

Minimum System

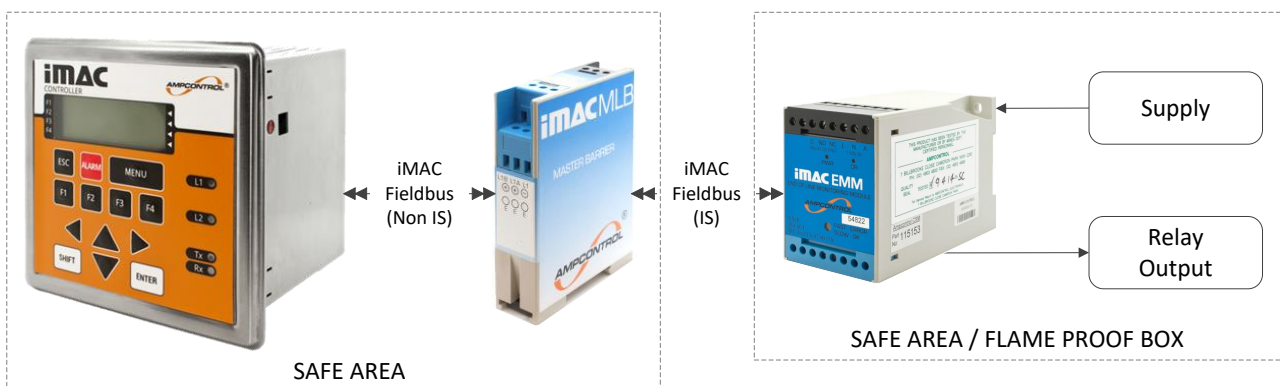

CAUTION!



Modules used in Non-I.S. systems shall not be re-used in I.S. systems (as the integrity of internal components upon which intrinsic safety depends may have been compromised).

Inductive loads must include transient suppression (snubber) to prevent output relay contact damage (refer to output relay ratings).

When connected to an iMAC intrinsically safe communication line, the iMAC EMM Relay must be installed in a safe area or a flameproof enclosure.

Electrical Connections

24 VDC Model

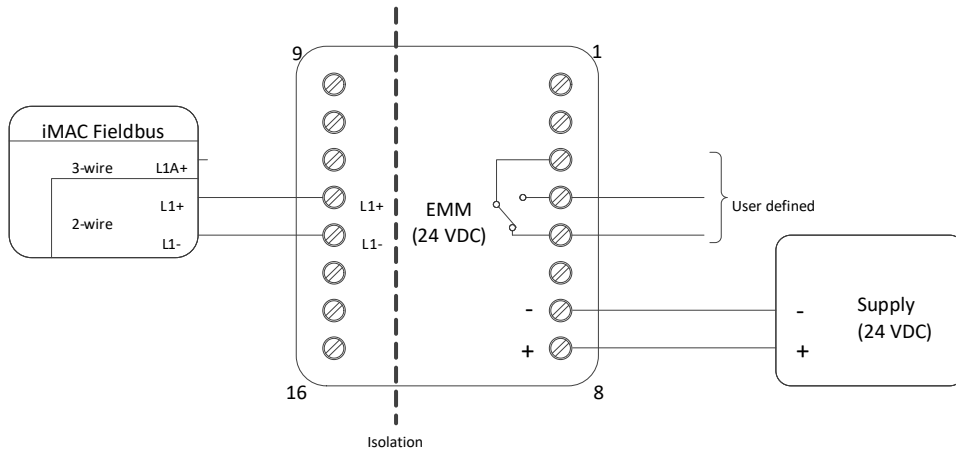

110 VAC Model

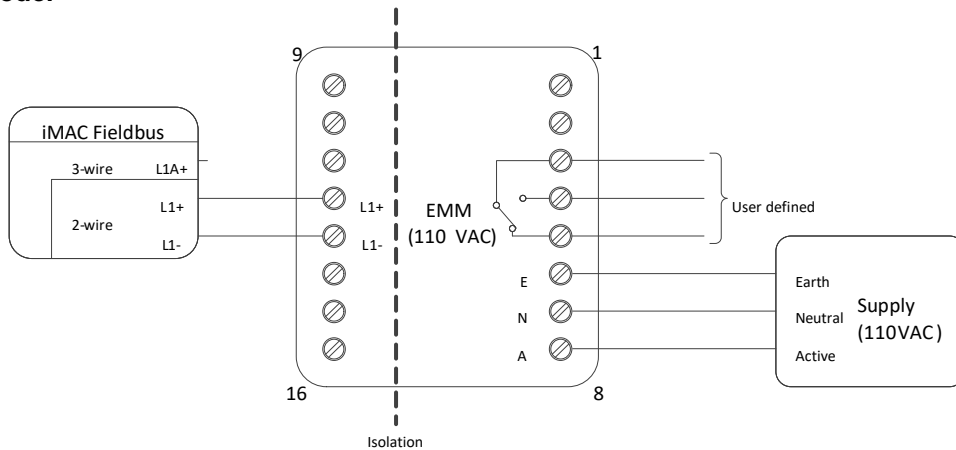

240 VAC Model

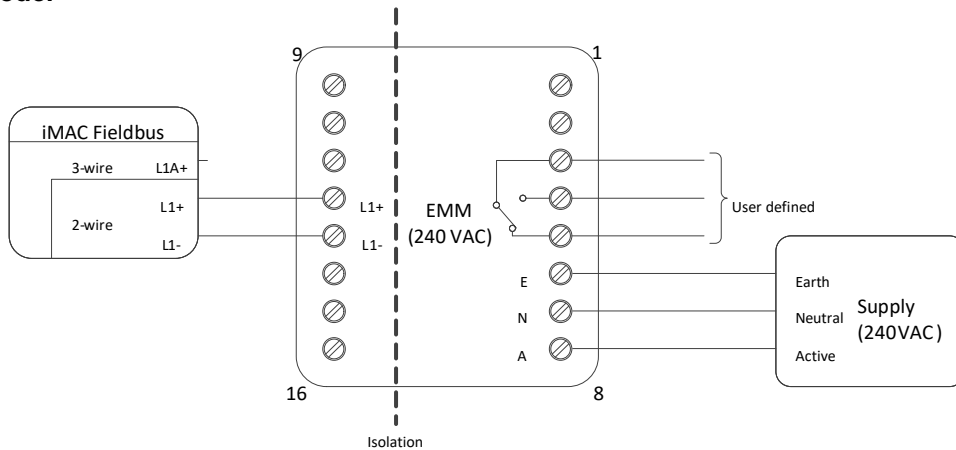

Note: refer to iMACB094 – iMAC Installation Requirements

Terminal	Label	Type	Description
1, 2	-	-	-
3	C	Relay output	Signal line healthy (CR alternative)
4	NO		
5	NC		
6	E	Power supply input	AC / DC – model dependent (E connection required for AC models only)
7	N / (-)		
8	A / (+)		
9, 10, 11	-	-	-
12	L1+	L1 Comms	iMAC Fieldbus (2 wire)
13	L1-		
14, 15, 16	-	-	-

Data Register(s)	
Register	
None	

Configuration Parameters

(Refer to document IMACB005 - iMAC module parameters programming procedure)

Register Parameters (roll-call name: EMM Module)					
No	Description	Range	Default	Units	R/W
1	Not used (Fixed at 0)	0	0	-	R
2	L1 comms – Invalid symbol counter	0 - 65535	0	-	R
3	L1 comms – Checksum error counter	0 - 65535	0	-	R
4	Not used (Factory use)	-	-	-	R

Functional Logic

The iMAC EMM Module will tolerate 1 bit of data corruption in 8 scans and the CR contacts will open immediately if there is no reply from the EOL (End of Line) Module or there has been more than 1 bit of data corruption within last 8 scans of EOL module data.

EMM Output Relay Status	
EOL Module	EMM Output Relay
Healthy	Energised
Failed	De-Energised

LED Indicators

Status LED (RED)			
Flash Sequence	Module - iMAC Comms Status		Module - Function Status
Off	Unknown (check connections)		Unknown (check connections)
Slow Flash	Healthy		-
2 Flashes	Healthy (has been roll-called)		-
3 Flashes	Error (address clash)		-
Fast Flash	Warn (general)		-
Power LED (PWR)			
Off	The module is not powered		
On	The module is powered		
Control Relay LED (CR)			
Off	Relay is de-energized		
On	Relay is energized		

IMACB143 EMM TECHNICAL DATASHEET
Version: 2, Date: 12 July 2024

Certification / Approvals	
Type	[Ex ia] I Ma
Certificate number	IECEX ITA 07.0017X
Module type	SA16
IP rating	Must be installed in an enclosure not less than IP20 (IP54 recommended)
Other	Must be installed in safe area or flame proof box Must be connected in accordance with iMAC system drawing IMACZ032 L1+ L1- terminals must only connect to a single MLB (Master Line Barrier)
I/O parameters	Terminals 1 - 8
	Terminals 12 wrt 13 (L1+ wrt L1-)
	Um = 250 V Ui = 21.5 V (44.65 R source resistor) Ci = Negligible Li = Negligible Uo = 0 V Io = 0 A
Ambient temperature (Ta)	-20 °C to +40 °C (refer to operating environment specifications)
This table is provided for quick reference purposes only; refer to latest issue of the Certificate of Conformity for all system designs.	

Specifications			
Mechanical			
Dimensions (H x W x D)	75 x 55 x 110 mm		
Weight	230 g		
IP Rating	IP20		
Mounting	Standard 35 mm DIN rail (Top Hat Rail – EN50022)		
Electrical Connections	ERNI screw terminals (maximum wire size of 4 mm ² , maximum torque or 0.4 Nm)		
Environmental			
Operating Temperature	0 °C to +50 °C		
Power Supply (external)			
Voltage	24 VDC (±15 %)	110 VAC (±15 %)	240V AC (±15 %)
Current (qty relays on)	7 mA (0) / 26 mA (1)	36.4 mA (4 W max)	16.7 mA (4 W max)
Relay Outputs (1 C/O)			
Limits	240 VAC @ 8 A (100 VA max) or 30 VDC @ 5 A (resistive) (100 VA max)		
Communications (iMAC L1)			
Hardware interface	2 wire (+/-18 VDC I.S. via MLB barrier or +/-21 VDC non I.S. iMAC Fieldbus)		
Line Speed	300 - 1000 baud		
Bit protocol	iMAC proprietary		
L1 Isolation	3.5 kV AC		
L1 Line Loading (baud)	Relay energised: 0.80 mA (300) / 1.32 mA (500) / 3.56 mA (1000)		
	Relay de-energised: 0.52 mA (300) / 0.82 mA (500) / 2.16 mA (1000)		
Find Out More			
For more information on this product, contact Ampcontrol Customer Service on +61 1300 267 373 or customerservice@ampcontrolgroup.com or visit the Ampcontrol website: www.ampcontrolgroup.com			

APPROVED FOR EXTERNAL DISTRIBUTION - PROPERTY OF AMPCONTROL PTY LTD - NOT TO BE REPRODUCED IN PART

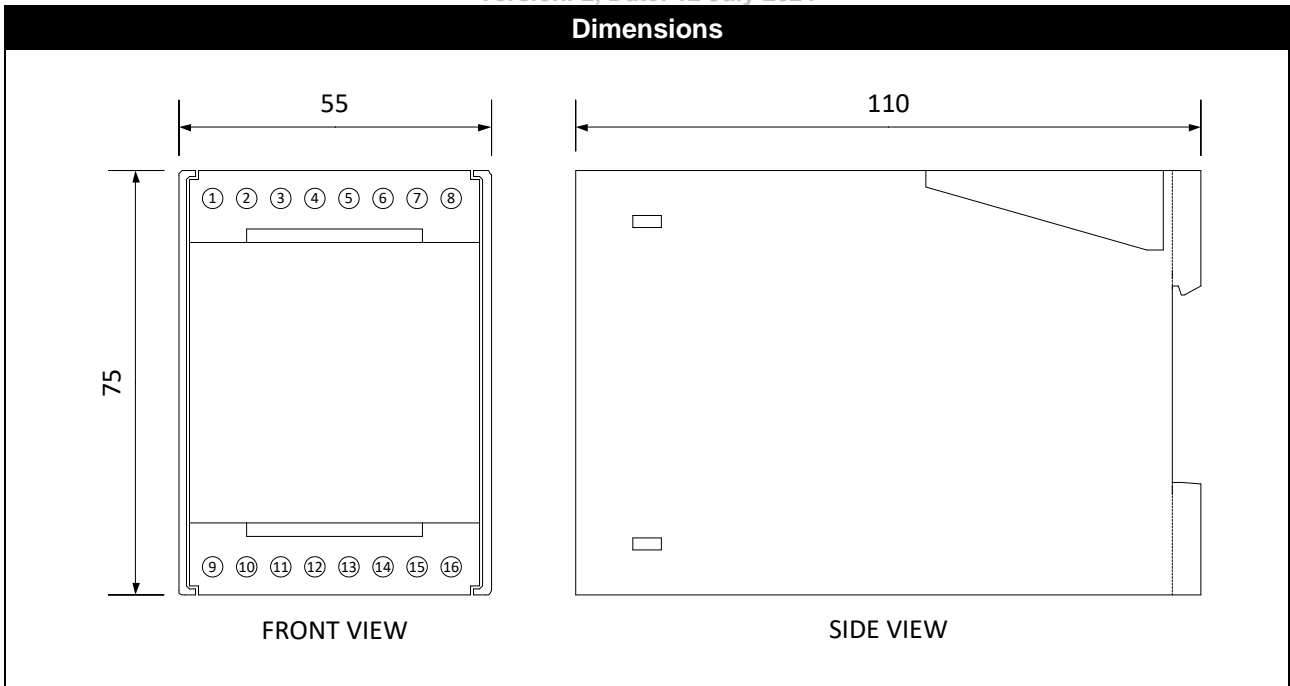

Equipment List	
Part Number	Description
144325	MODULE IMAC EMM 24VDC IECE _x
115153	MODULE IMAC EMM 110V IECE _x
115154	MODULE IMAC EMM 240V IECE _x

APPROVED FOR EXTERNAL DISTRIBUTION - PROPERTY OF AMPCONTROL PTY LTD - NOT TO BE REPRODUCED IN PART

DISCLAIMER

While every effort has been made to ensure the accuracy of this document at the date of issue, Ampcontrol assumes no liability resulting from any omissions or errors in this document, and reserves the right to revise content at any time.