

PF1 PUMP & FAN PROTECTION RELAY

Electrical Protection Relays

Application

The Ampcontrol PF1 Protection Relay is a multi-functional Relay designed for hard rock mining applications on electrical outlets supplying Pump or Fan motors. When applied correctly, the specialised pump and fan protection modes can significantly reduce the risk of damage to equipment and thus can also considerably reduce maintenance requirements.

The PF1's Pump and Fan operating modes can both be disabled, allowing the PF1 to also operate as a combined Earth Leakage and Earth Continuity relay on non-pump and non-fan outlets. This has the added advantage of reducing Relay variants used across a given site (reduced stock, spares, maintenance and operator training costs).



Description

The PF1 has the ability to perform two standard protection functions which are compliant to AS/NZS2081:2011 for Earth Leakage and Earth Continuity. In addition to these protection functions, the PF1 also provides selectable control functionality for Pump or Fan motor installations.

The Pump Protection Mode manages the no-load/under-current condition of a pump by monitoring the load current. When the load on the pump motor decreases due to the intake pipe not being fully submerged (known as snoring), the speed of the pump motor will rise to its maximum, which can burn out the pump motor in as little as 30 seconds. The under-current condition is detected by the PF1 which can apply a configurable sleep/run cycle to help prevent pump burnout due to a lack of water.

The Fan Protection Mode manages the gradual pre-inflation of flexible ventilation conduit, by applying a pulsed (burp) start-up sequence to the fan motor. This can prevent damage to the material of the ventilation tube during the initial stages of inflation.

The four protection/control functions of the PF1 can be independently enabled or disabled through Smart Tools. Smart Tools is a free Windows software package, supplied with the PF1, which enables the user to configure the PF1 via the supplied USB cable.

Features

- Earth continuity protection function (AS/NZS 2081:2011 compliant)
- Earth leakage protection function (AS/NZS 2081:2011 compliant)
- Selectable pump protection mode (Anti-Snore Mode)
- Selectable fan protection mode (Burp Mode)
- 24Vac or 24Vdc operation
- DIN rail mounted
- LED status indication to aid in fault finding
- Event data logging
- Configurable parameters via USB connection to PC running Smart Tools software (Windows 10 only)
- Automatic Firmware updates via Smart Tools v6+

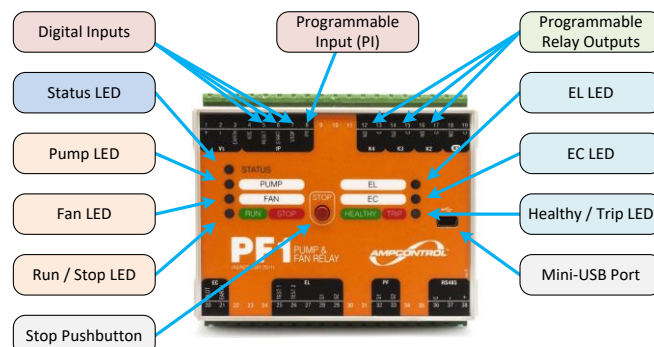

MAG-164 PF1 TECHNICAL DATASHEET
Version: 8, Date 23 MARCH 2021

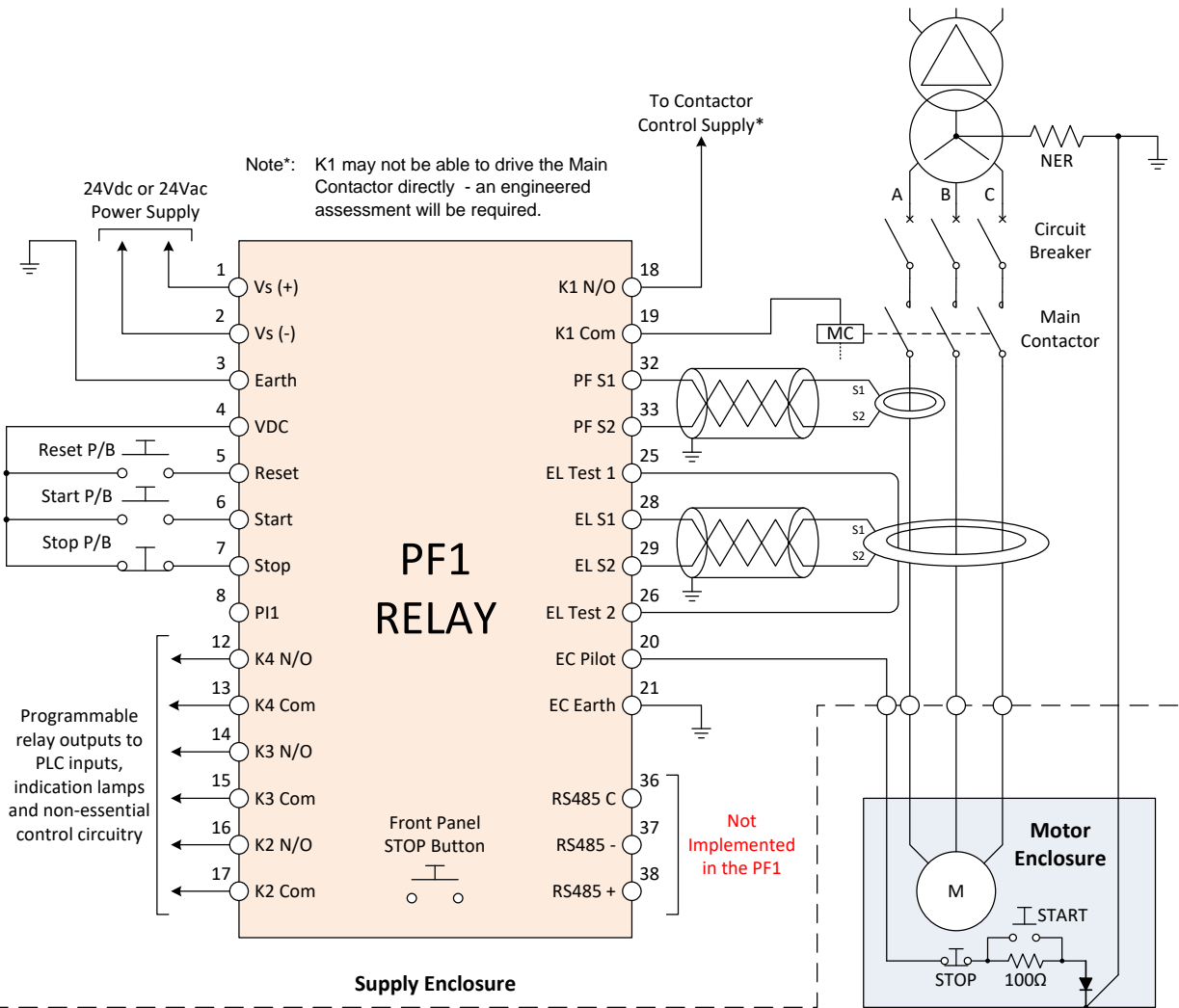

Specifications	
General	
Compliance	(AS/NZS 2081:2011)
Supply	
Regulated Voltage	18 to 28.8Vdc or, 18 to 28.8Vac 50 to 60Hz
Impulse Voltage (max)	50V peak for 200ms
Power Consumption	10VA
Relay Contacts	
Contact Rating	110Vac / 30Vdc 1A (Resistive)
Pump & Fan	
Toroid	CT 1000/1 50mm PFCT SRS27
Toroid Ratio	1000 : 1
Primary Input Current	1 to 200A
Accuracy	± 5% ± 0.5A (@50Hz)
Toroid Window Size	50mm Inner Diameter
S1/2 cable loop resistance (max)	0.1 Ω
S1/2 length (max)	10m
S1/2 cable type	Twisted pair + shield to Earth (on PF1 end only)
Earth Leakage	
Trip Times	50 to 500ms
Trip Levels	30 to 100mA
Toroid	EL500/60 or EL500SP1 (requires firmware V6+)
Toroid Ratio	100 : 1
Toroid Output Power (Max)	15VA
Toroid Window Size	60mm Inner Diameter
Passband	Wide Band Mode: 30 to 500Hz 50Hz Mode: 30 to 90Hz

MAG-164 PF1 TECHNICAL DATASHEET
Version: 8, Date 23 MARCH 2021

Earth Leakage – Continued	
S1/2 cable loop resistance (max)	0.1Ω
S1/2 length (max)	10m
S1/2 cable type	Twisted pair + shield to Earth (on PF1 end only)
TEST1/2 cable loop resistance (max)	2Ω
TEST1/2 length (max)	10m
TEST1/2 cable type	Twisted pair
Earth Continuity	
Trip Times	50 to 500ms
Trip Levels (Series)	10 to 45Ω
Trip Levels (Shunt)	1250Ω
Pilot Output Signal Voltage	<30Vdc
Pilot Cable	C _{max} = 0.25μF L _{max} = 0.70mH
Terminating Diode	1N5404 3A
Remote Start Resistor	100R 1% 5W
Mechanical & Environment	
IP Rating	IP20
Operating Temperature Range	-10 to 60°C
Storage Temperature Range	-20 to 70°C
Humidity	Between 10% relative humidity and the dew point, non-condensing
Dimensions (mm)	With Plugs: 100w x 105h x 110d Without Plugs: 100w x 85h x 110d
Terminal Wire Gauge (Max)	2.5mm ² (with bootlace ferrule)
Weight (Kit)	3kg (PF1 Relay: 500g, EL Toroid: 1500g, PF CT: 650g, Packing: 300g)
USB Interface	
Type	USB Mini
Current Consumption	75mA (when supply voltage is not energised)
Find Out More	
For more information on this product, contact Ampcontrol Customer Service on +61 1300 267 373 or customerservice@ampcontrolgroup.com or visit the Ampcontrol website: www.ampcontrolgroup.com	

Ordering	
Part Number	Description
174403 (KIT)	Kit Relay PF1 Pump & Fan c/w Toroids. This includes: <ul style="list-style-type: none"> Relay PF1 Pump & Fan (P/N 173563) Current Transformer - 50mm Inner Diameter (P/N 175616) Earth Leakage Toroid - 60mm Inner Diameter (P/N 115439) or (P/N 178810: requires firmware V6+) EC Diode 1N5404 3A (P/N 117023) EC Start Resistor (P/N 169732)
173563 (RELAY)	Relay PF1 PUMP+FAN. This includes: <ul style="list-style-type: none"> PF1 Pump & Fan Relay 2x 19 way field pluggable screw terminal blocks USB Drive with Smart Tools PC software, User manual and Datasheet USB Type A to Mini-USB Cable (1m) EC Terminating Diode - 1N5404 3A (P/N 117023) EC Start Resistor - 100R 1% 5W (P/N 169732) <p>Note: Requires approved Earth Leakage toroid for 2081 compliance. Refer to Kit.</p>
175616	Current Transformer - 50mm Inner Diameter (Included in Kit)
115439 or 178810*	Earth Leakage Toroid - 60mm Inner Diameter (Included in Kit) (*178810 requires firmware V6+)
117023	EC Terminating Diode - 1N5404 3A (Included in Kit)
169732	EC Start Resistor - 100R 1% 5W (Included in Kit)

DISCLAIMER

While every effort has been made to ensure the accuracy of this document at the date of issue, Ampcontrol assumes no liability resulting from any omissions or errors in this document, and reserves the right to revise content at any time.